

OxyGuard[®]

Commander

System and Component

Examples

October 2007

C00 Commander System and Component Examples 1007

SOME BASICS

A Commander system is a process control system that can control an entire fish farm. Commander is an OxyGuard product, and as such the focus is on water quality monitoring and control. Dissolved oxygen is paramount, and each Commander DO probe also has a built-in temperature measurement. Commander has PID control functions for these parameters that can be activated as desired. This form of control gives very steady values which, for example, can mean a saving of 30% in the use of oxygen.

Any other parameter can be fed to a Commander system, either as an on/off signal or analogue signal, and used to regulate outputs. Commander also has alarm functions and data logging functions as well as sub-systems for pump control, lighting control, feeder control and similar that can be incorporated as desired. Information can be exchanged between Commander and farm management systems, and it is easy to export data from Commander to Excel or other spread sheet programs.

Commander systems operate using a field bus data link to communicate between the various component parts. Control is distributed - most of the control and data logging is placed in one or more Master Units, but the Dissolved Oxygen Meters can in fact measure and display dissolved oxygen and temperature as independent devices.

Interface between an operator and Commander is made via a PC screen. Even though it appears to be the PC that controls the system this is NOT the case - the Master Unit or units performs the control, the PC "just" gives the operator access - easy access - to the system. Logged data is also automatically transferred to the PC.

A LAN option permits the Commander system to function as an entity on a Local Area Network. This makes it very easy to communicate with, as any computer on the network with proper software and security setup can then be used.

It should be noted that the graphical interface shown on the PC is quite demanding with regard to display, so it is not recommended to run the Commander program together with another program needing substantial CPU capacity, for example to control other hardware.

Commander systems can be shipped pre-programmed and ready to use, with clear identification of the components so that installation is made very easy.

There are three main categories of Commander system, all with data logging, alarm functions etc:

- 1) Simple Dissolved oxygen (DO) & Temperature monitoring.
- 2) DO & Temperature monitoring, with oxygen injection control. Perhaps monitoring of other parameters - e.g. level and pH.
- 3) Complete control of the entire farm:
Dissolved oxygen and temperature measurement and monitoring with data logging; oxygen injection control and the monitoring and control of pumps, filters, blowers, valves etc; lighting control, feeder control, monitoring of other parameters.

GROUPING

Most Commander systems consist of a **Master Box**, a number of **DO Meters with Probes**, an **Input Box** (or boxes) and an **Output Box** (or boxes). These are connected together by a field bus data cable (P-NET cable).

Very simple or small systems, e.g. without oxygen dosing control, will probably not need input boxes or output boxes.

Very large systems (for example with more than 80 DO measurements) can consist of two (or more) interconnected Master Boxes with input and output boxers and DO meters.

Sometimes physical position - distance - or the need to operate one section completely separately from the rest - dictates that two Master Box sections are used.

Sometimes boxes are not used - the parts needed are then mounted into the main electrical control cabinet for the farm concerned by the project electrician.

Commander system with one Master Box

This is an example - the actual number of DO meters, Input Boxes and Output boxes will depend on the actual installation. Here the main PC is usually connected to the Master Box using a field bus connection. For security the outward internet connection is made to a PC dedicated to that purpose.

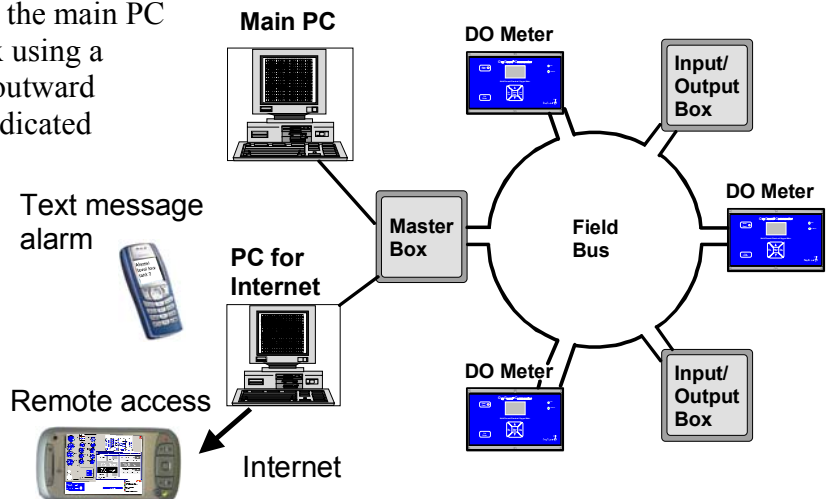

Text messages can be sent to pre-programmed telephone numbers, after which appropriate action can be taken. This can include complete control from a remote computer, using special precautions to ensure security.

Commander system with two Master Boxes

This is also an example. Connection between the Master Boxes and the PC's is made using LAN.

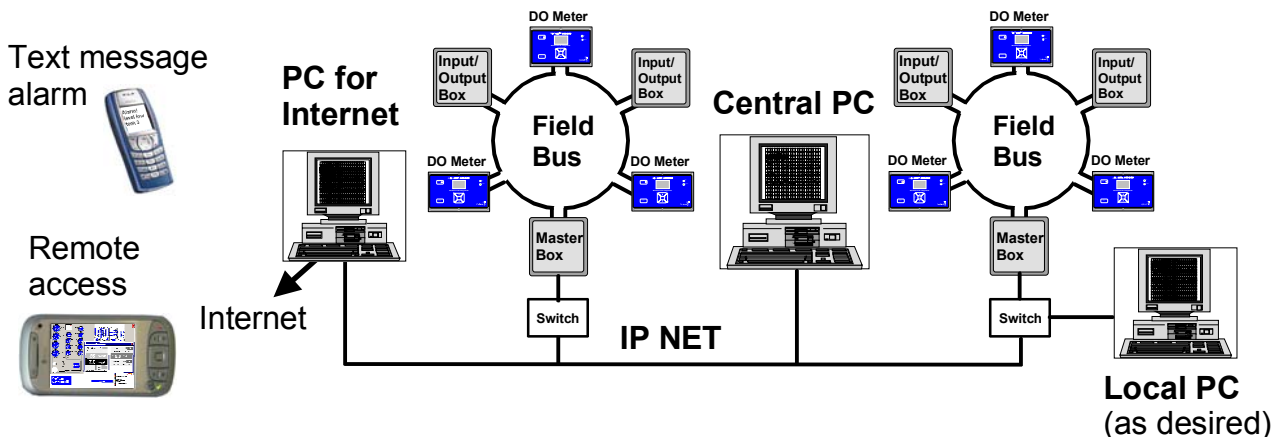

MASTER BOX

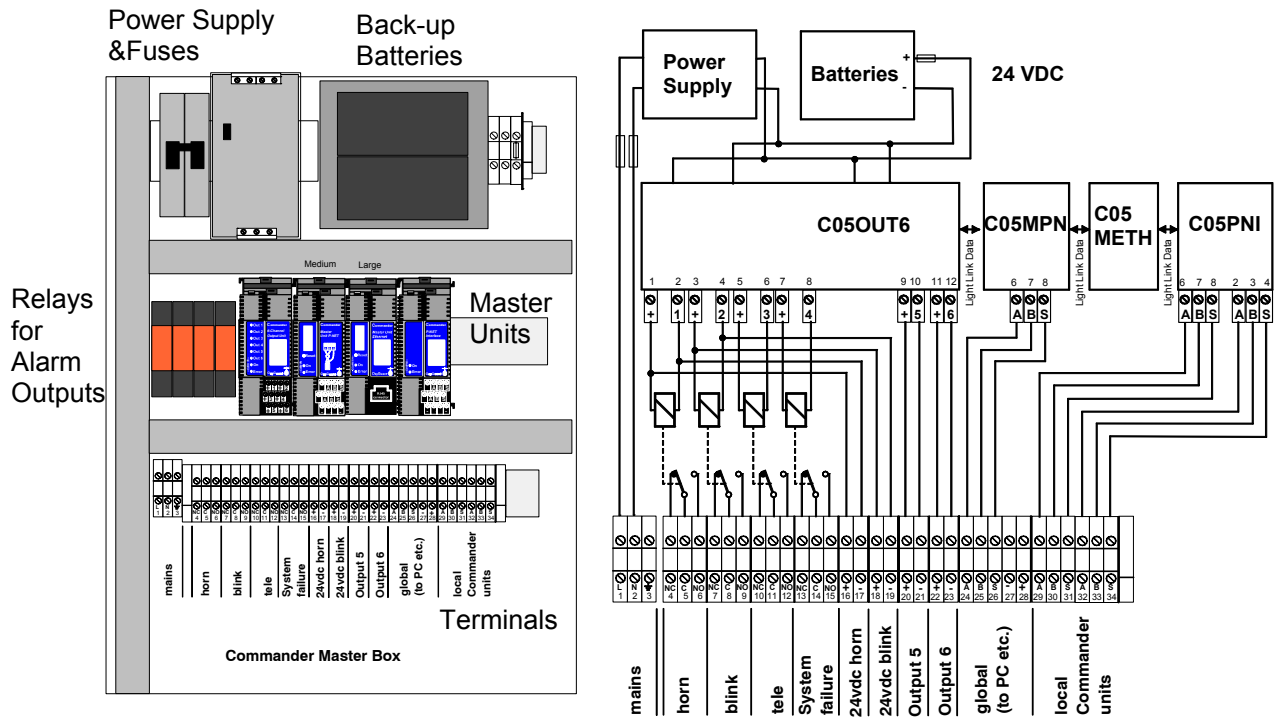

Dimensions: h x w x d 53 x 43 x 20 cm

A **Master Box** contains a power supply with battery back-up, terminals, alarm horn and light and components clipped together on a rail with a light bus interconnection. It is delivered wired, ready for mounting and connection to P-NET, power and alarm connections as desired. As standard it has four alarm contact outputs. Other Master Units can be added to perform additional data logging, feed control, lighting control etc.

The Master Box forms the "heart" of a Commander system, and it is delivered together with basic software and an adapter for connection to a PC.

The components include:

- Master unit for input/output control (C05MPN).
- Master Unit for 100 channels of data logging and Ethernet connection (C05METH).
- Interface unit for Light Link to data cable (C05PNI).
- Power Supply 230 V AC to 24 V DC, battery charger and back-up battery.
- Automatic fuses.
- 6 channel on/off output unit (C05OUT6).
- Terminals for P-NET and power.
- 4 relays each with one potential free changeover contact.
- Alarm horn and strobe light.
- Software for use with one PC and P-NET to PC adapter C05PCPNA.

The Master Box can be supplied as separate components for mounting in an electrical control cabinet - please consult OxyGuard for further details.

INPUT AND OUTPUT BOXES

Input Box Example

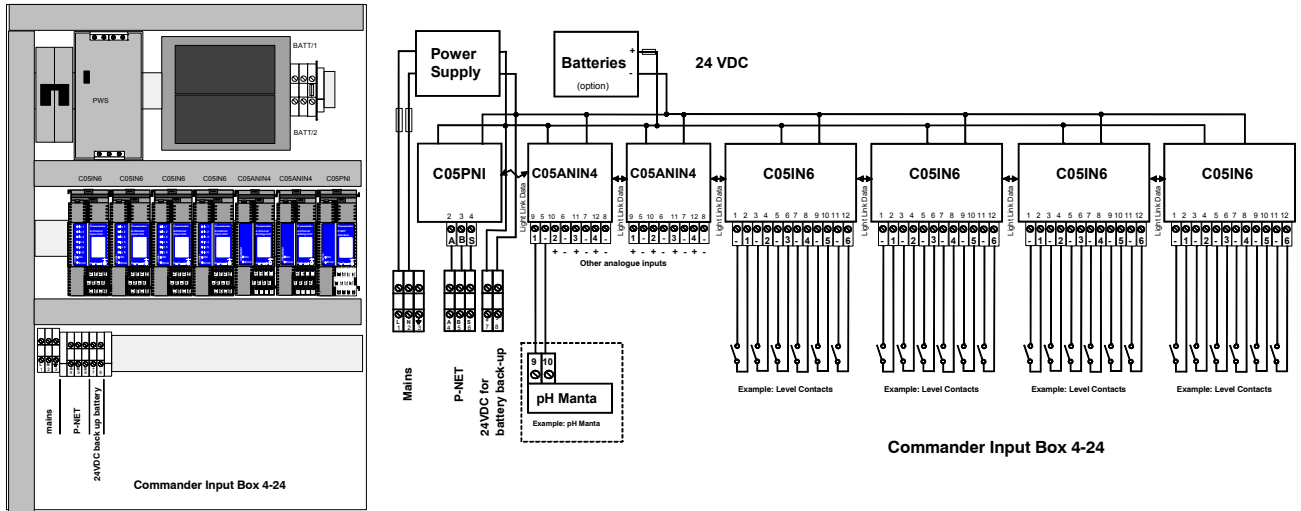

The above example shows an input box with 8 analogue input channels (for example for CO₂, pH, ORP, flow and UV inputs) and 24 on/off input channels (for level and equipment state).

Output Box Example

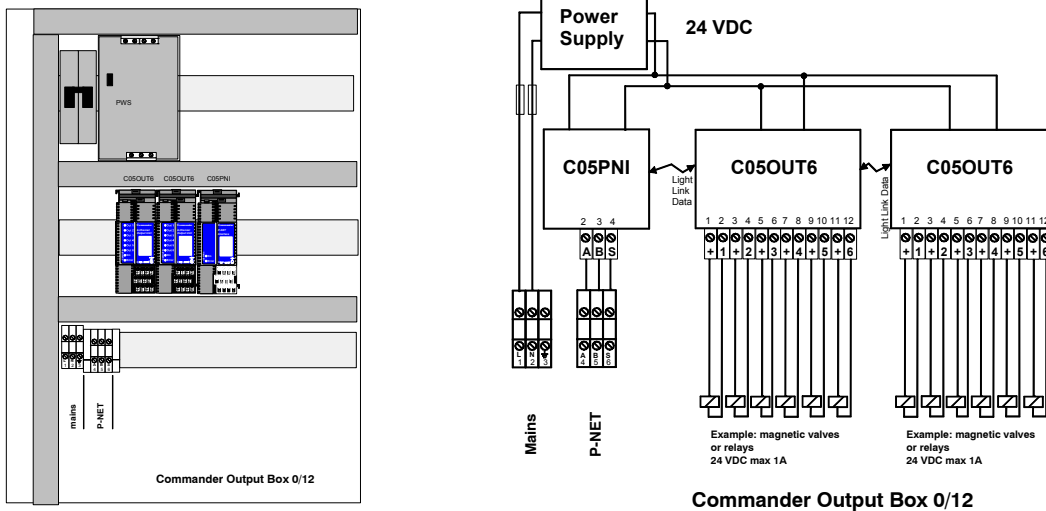

The above output box example has 12 on/off channels that, for example, can be used to switch magnetic valves for oxygen injection. A 10A power supply is included to power the magnetic valves - each channel can in this case thus deliver 0.83A continuously. The maximum for each output channel is 1A.

The number of boxes used in each system should be chosen so that the positioning of components such as level switches and magnetic valves for dosing can be optimised whilst keeping cabling to valves and level switches short.

DISSOLVED OXYGEN METERS AND PROBES

Dissolved oxygen is measured using the Commander DO Meter. This unit does not just measure dissolved oxygen, but measures dissolved oxygen in mg/l (ppm), dissolved oxygen in % saturation, temperature and barometric pressure.

Up to 6 Commander probes, that measure both DO and temperature, can be connected to a unit. One, two or three input modules ("input amplifiers") are inserted according to the number of probes connected - each module can treat the signals from one or two probes. Onward connection is by P-NET field bus. Measured values can be observed on the display of the unit. Green LED indicators show when the unit is powered and when there is connection to the P-NET. A red LED indicator shows when there is an alarm condition.

The DO Meter can measure even if connection to the rest of the system is broken



probe diameter 58 mm, height 589 mm
probe delivered with 7 m cable

DO Meter
w x h x d 250 x 160 x 125 mm

The **DO Meters** are placed as appropriate near the tanks or ponds etc. It is often better to use an extra DO meter close to the points of measurement rather than to establish long connections in order to use all the channels available on each DO meter.

Oxygen dosing control is carried out using one or two switched supplies of oxygen to each tank. On/off output signals from Output Boxes are used to pulse magnetic valves. The more oxygen is needed, the longer the valve stays open. PID algorithms are used to give very close control of oxygen levels. Magnetic valves and flowmeters can be used as in the following illustrations:

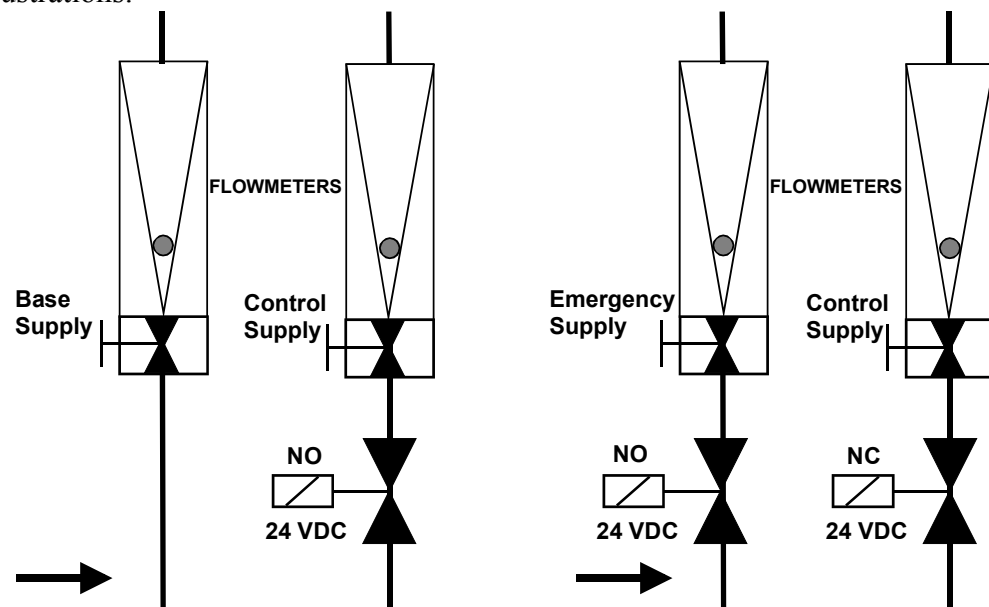

pH MEASUREMENT AND CONTROL

pH is measured using a pH Manta meter with 4-20 mA output that is fed to an analogue input module in an Input Box.

pH control is usually effected using on/off output units in Output Boxes to control magnetic valves to dose chemical solutions. As with oxygen injection, true PID control can be achieved using pulsed dosing with duty cycle variation. To prevent continuous dosing in the event of a fault such as a power failure the magnetic valves used to dose the chemicals should be powered to open, i.e. should shut closed in the event of power failure.

Instead of components in input boxes and output boxes special pH control boxes with all the components for pH control can be provided.

pH Measurement and Control

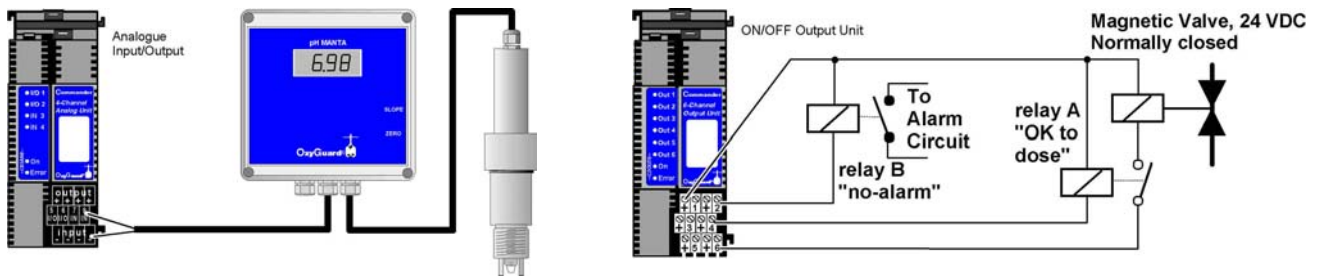

CO2 MEASUREMENT



Dissolved carbon dioxide can be measured and monitored using the OxyGuard CO2. This has a 4-20 mA output that can be connected to a Commander input unit for monitoring and alarm or to start any appropriate action.

CONTROL OF PUMPS, FILTERS ETC

The following examples show how Commander can control pumps, filters etc. "C05IN6" is the Commander 6 channel input unit; "C05OUT6" the 6 channel output unit and "C05ANIN4" is the Commander analogue unit.

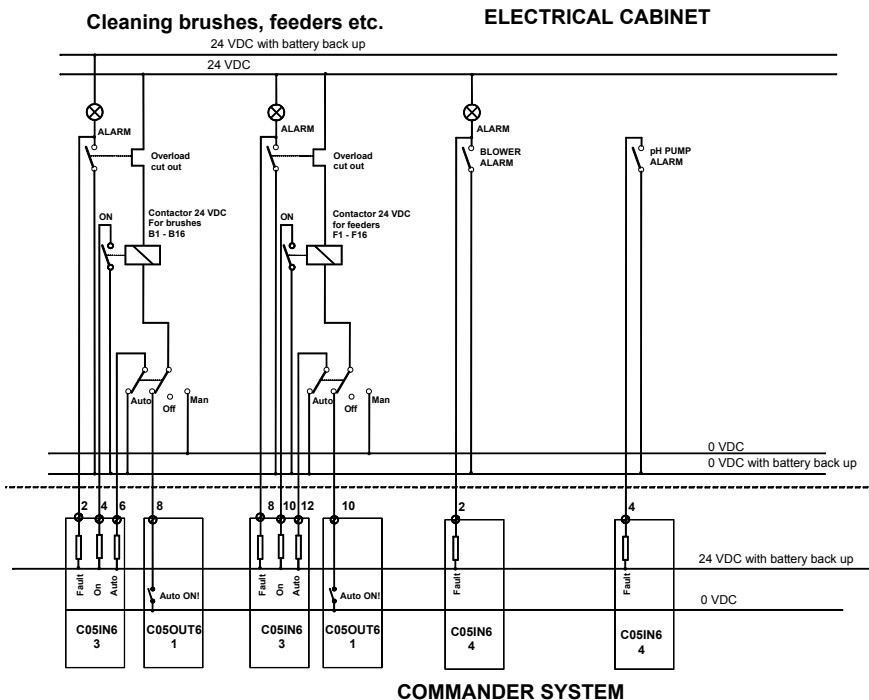
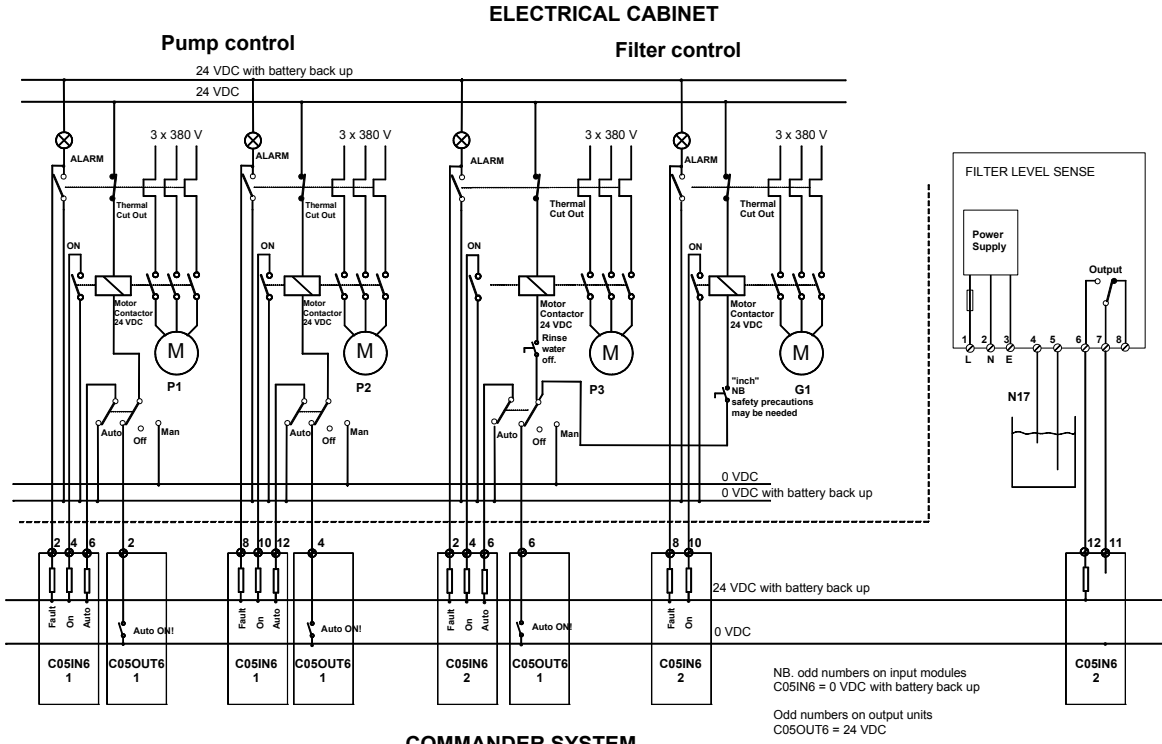

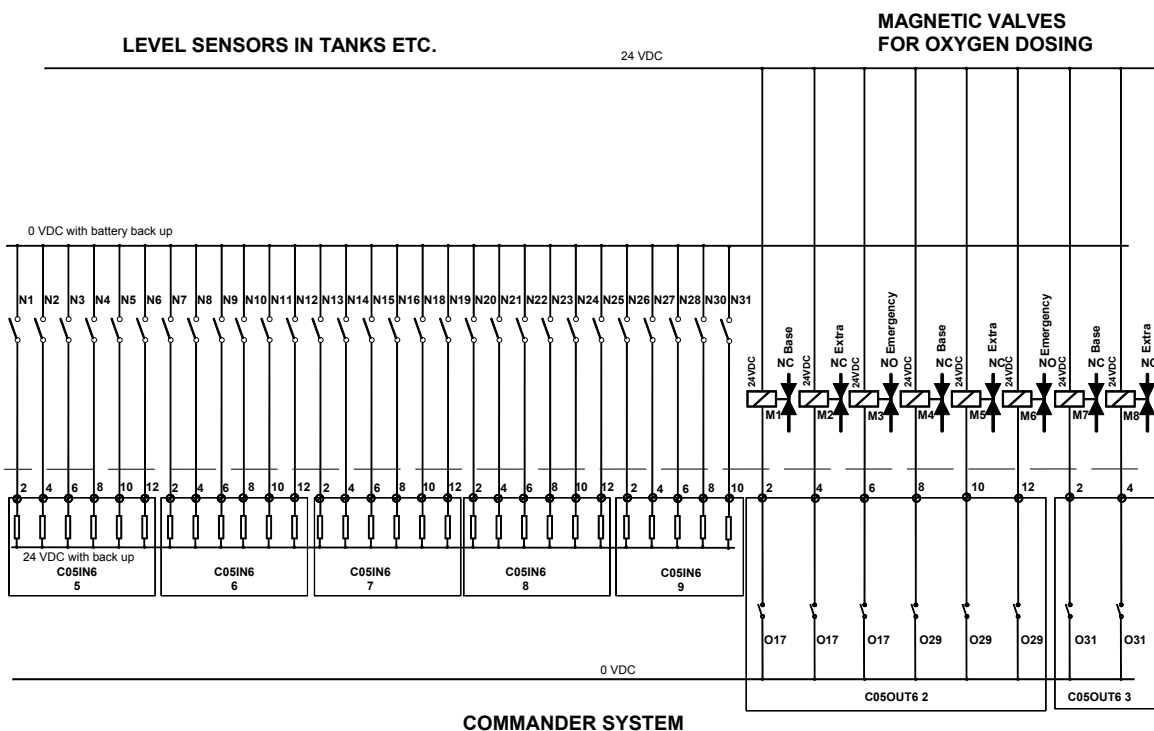

The input and output units illustrated above can be placed in input boxes and output boxes, but they can also be mounted in the main electrical control cabinet. The following picture shows some Commander units in such a large cabinet. Please consult OxyGuard for further details of such solutions.



LIGHTING CONTROL AND FEEDER CONTROL

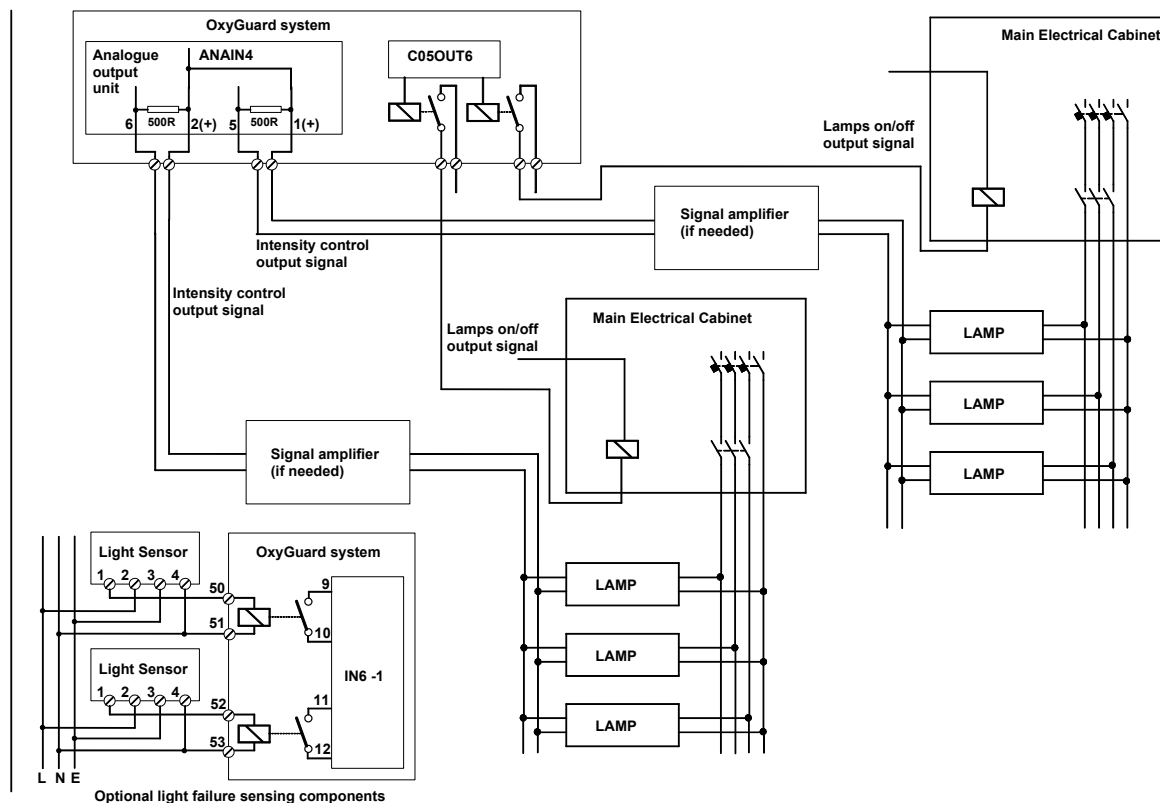

A special software for Commander makes it possible to automatically **control artificial lighting to simulate natural daylight**. The "daylight" period increases or decreases automatically. It is also possible to measure the actual light intensity so that the artificial lighting is used to supplement the actual sunlight as needed.

This software can also be used to **control feeders**. The amount of feed needed is calculated using a feeding program. The Commander feeder control is then used to dose this amount of feed in an appropriate manner.

Please see the separate brochure for this program.

OTHER ITEMS

DESIGN

A graphical design that displays the installation on the PC screen is specially programmed for each Commander system. The various measurements and components are shown on the PC screen. If there is an alarm or situation that needs attention the device concerned is displayed in red or a similar colour to alert the operator. By clicking on the device details are obtained and action can be taken.

TEST, COMMISSIONING ETC.

OxyGuard can provide on-site test and commissioning so that the user is presented with an up-and-running system.

EXTRA SOFTWARE

Commander is very versatile, and a Commander system can be observed and, if desired, controlled from a computer placed far away from the site. Such connection has been used between Denmark and Chile. The purchase of extra software is necessary.

CABLE AND ACCESSORIES

The only cable requiring special consideration is the P-NET cable, which should be a suitable data cable. Probe leads can be extended using ordinary 4 core cable, minimum conductor cross section 0.25 mm².

We recommend the use of watertight junction boxes when extending probe cable.

EXTRA OR LOCALLY SOURCED ITEMS AND WORK

The following items must be provided or performed:

Provision of mains power.

Mounting of boxes, DO meters, probes etc.

Connection of all components - DO probes, DO meters, boxes, input and output signals as required, as well as P-NET field bus loop.

PLANNING

To plan a Commander system the following must be known:

- 1) The layout of the installation.
- 2) The inputs to be measured or monitored.
- 3) The outputs to be controlled (and what sort of control is wanted).
- 4) The number of places inputs and outputs are to be collected together in.
- 5) What data logging is desired.
- 6) Which inputs should control which outputs, and what form of control is wanted.

The following types of input and output should be considered:

Combined Dissolved Oxygen and Temperature measurements in tanks with fish
Is oxygen dosing control wanted, and if so with one or two outputs per tank.

Other combined DO and temperature measurements and oxygen control outputs

Other temperature measurements, e.g. air temp or water where DO is not measured

pH

ORP

Level

Flow

Ozone

CO₂

Other

Pump motors (speed control?)

Filter motors

Lighting control

Feeder control